

# SBD-110GP1

Wall Adaptor



## Key Features

- Color: White
- Material: Bottom-Aluminum, Top-Plastic
- Dimensions/ Weight:  $\phi 140 \times 12.2 \text{mm} (\phi 5.52 \times 0.56") / 181 \text{g} (0.39 \text{lb})$
- Mount Screw size: TR20

## Compatible Devices



QNV-C8011R



QNV-C8012



QNV-C9011R



QND-6011



QND-6021



QND-8011



QND-8021



QNF-8010



QNF-9010



QND-6012R



QND-6022R



QND-7012R



QND-7022R

# SBD-110GP1

Wall Adaptor



## Specifications

Mechanical	
Color	White
Material	PC(Polycarbonate), Aluminum
RAL code	RAL9003
Product dimensions / weight	ø140x12.2mm / 181g
Mount Screw size	TR20
Supported products	QNV-C8011R, QNV-C8012, QNV-C9011R ※ For further compatible models, please visit our website or use Toolbox

# SBD-110GP1

Wall Adaptor



CAD

Unit: mm [inch]

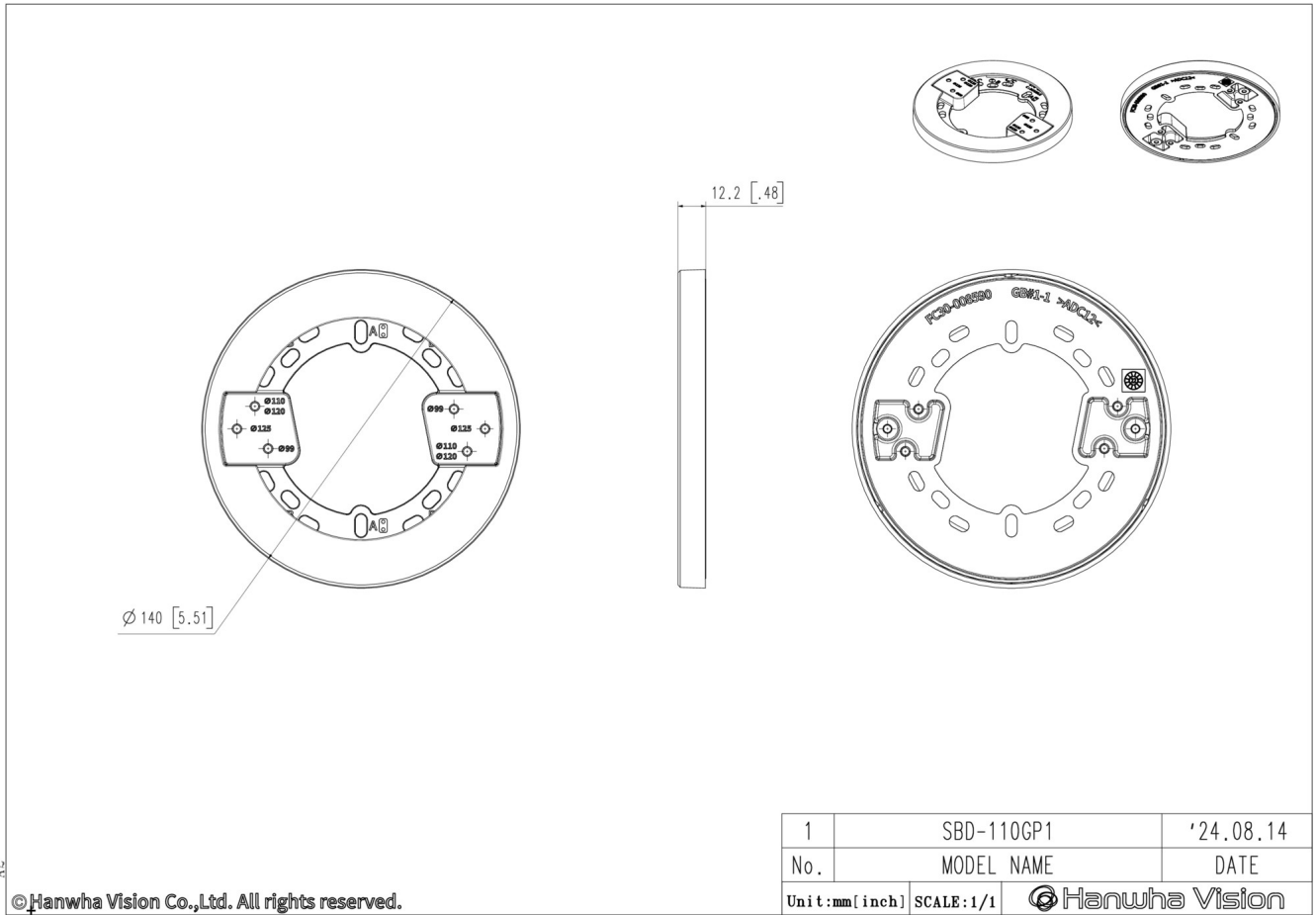

© Hanwha Vision Co., Ltd. All rights reserved.