



SBP-099HMW

Hanging Adaptor



Key Features

- Material: Aluminum
- Dimensions : Ø107 x 47mm (4.21' x 1.9')
- Weight : 133g (0.293 lb)
- Color : White
- Mount screw size : PF 1 1/2"
- Supported products : QND-8021/8011/6021/6011, QNF-9010/8010
- For further compatible models, please check out Wisenet Toolbox Plus

SBP-099HMW

Hanging Adaptor



Specifications

Mechanical	
Color	White
Material	Aluminum
RAL code	RAL9003
Product dimensions / weight	ø107
Max. load	2kg
Supported products	QND

SBP-099HMW

Hanging Adaptor



CAD

Unit: mm [inch]

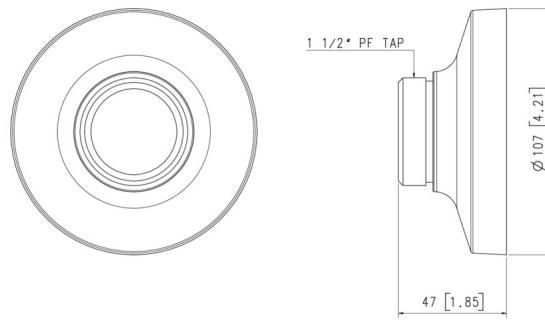

3		
2		
1	SBP-099HMW	'20.02.07
No.	MODEL NAME	DATE
Unit:mm [inch]	SCALE:1/1	

© Hanwha Techwin Co.,Ltd. All rights reserved.