



SBP-300WMW

Wall Mount



Key Features

- Mount screw size : PF 1 1/2"
- Color : White

SBP-300WMW

Wall Mount



Specifications

| Mechanical | |
|-----------------------------|---|
| Color | White |
| Material | Aluminum |
| RAL code | RAL9003 |
| Product dimensions / weight | 276.5x112x183mm / 730g |
| Mount Screw size | M10 |
| Max. load | 10kg |
| Supported products | SBP-120HMW, SBP-140HMW, SBP-160HMW1, SBP-180HMW1 ※ For further compatible models, please visit our website or use Toolbox |

SBP-300WMW

Wall Mount



CAD

Unit: mm [inch]

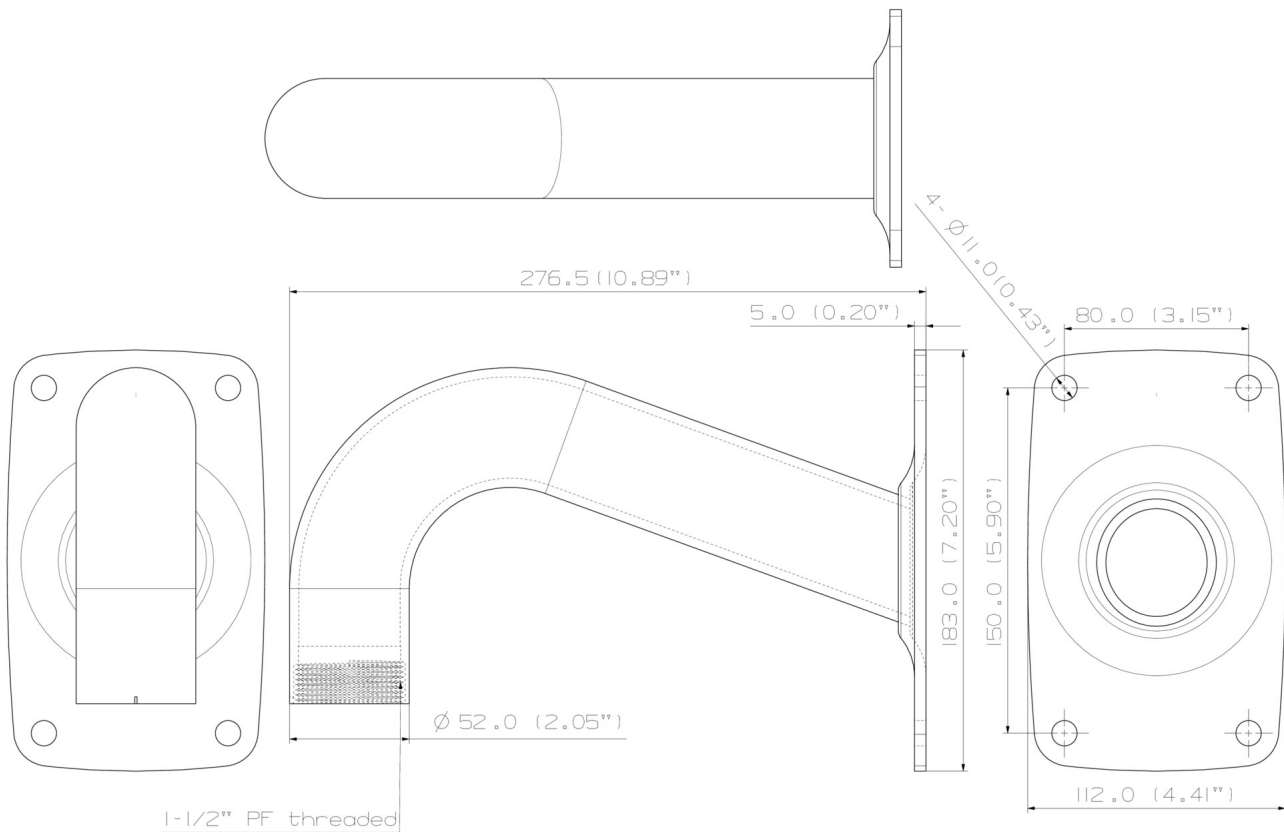

SCX-300WM Unit : mm (inch)